

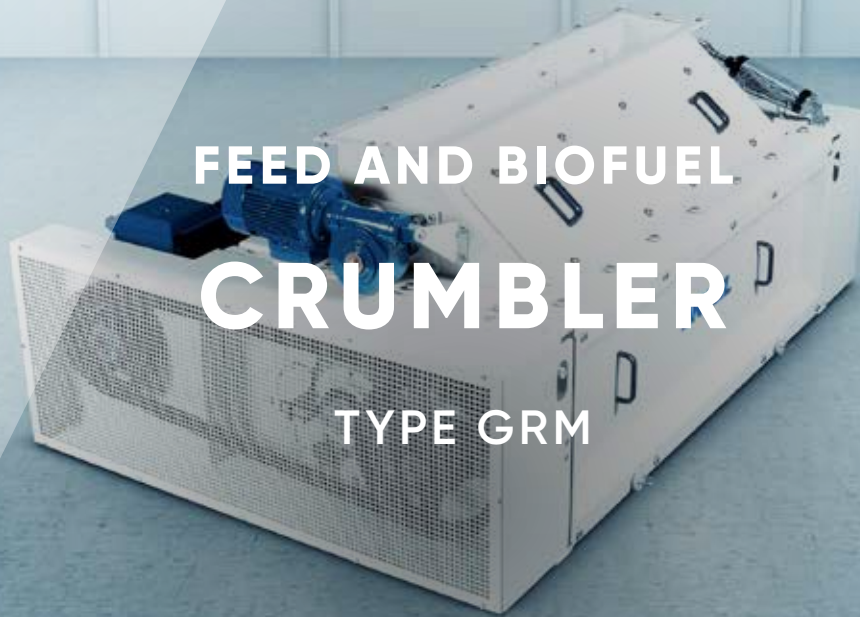

FEED AND BIOFUEL CRUMBLER TYPE GRM



ANDRITZ manufactures and offers two sizes of GRM heavy-duty, high-quality, high-capacity crumblers for crumbling animal feed pellets of any kind, with capacities extending from 20 tons/hour up to 60 tons/hour. Both models can comfortably process individual cereals and full recipes at high capacities and to your requested structure.

The ANDRITZ advanced feeding system provides precise, uniform feeding over the full length of the rolls, securing perfect performance, longest lifetime, and lowest energy consumption.

ANDRITZ testing tools included with your new crumbler allow sample-taking during operation to ensure

that you have the perfect product. Both models allow installation of the ANDRITZ automatic roll adjustment system and are, of course, controlled by the ANDRITZ advanced automation control system, which also allows individual settings for the crumbling process in order to obtain the perfect individual product. All features can also be added easily at a later date.

ANDRITZ

ENGINEERED SUCCESS

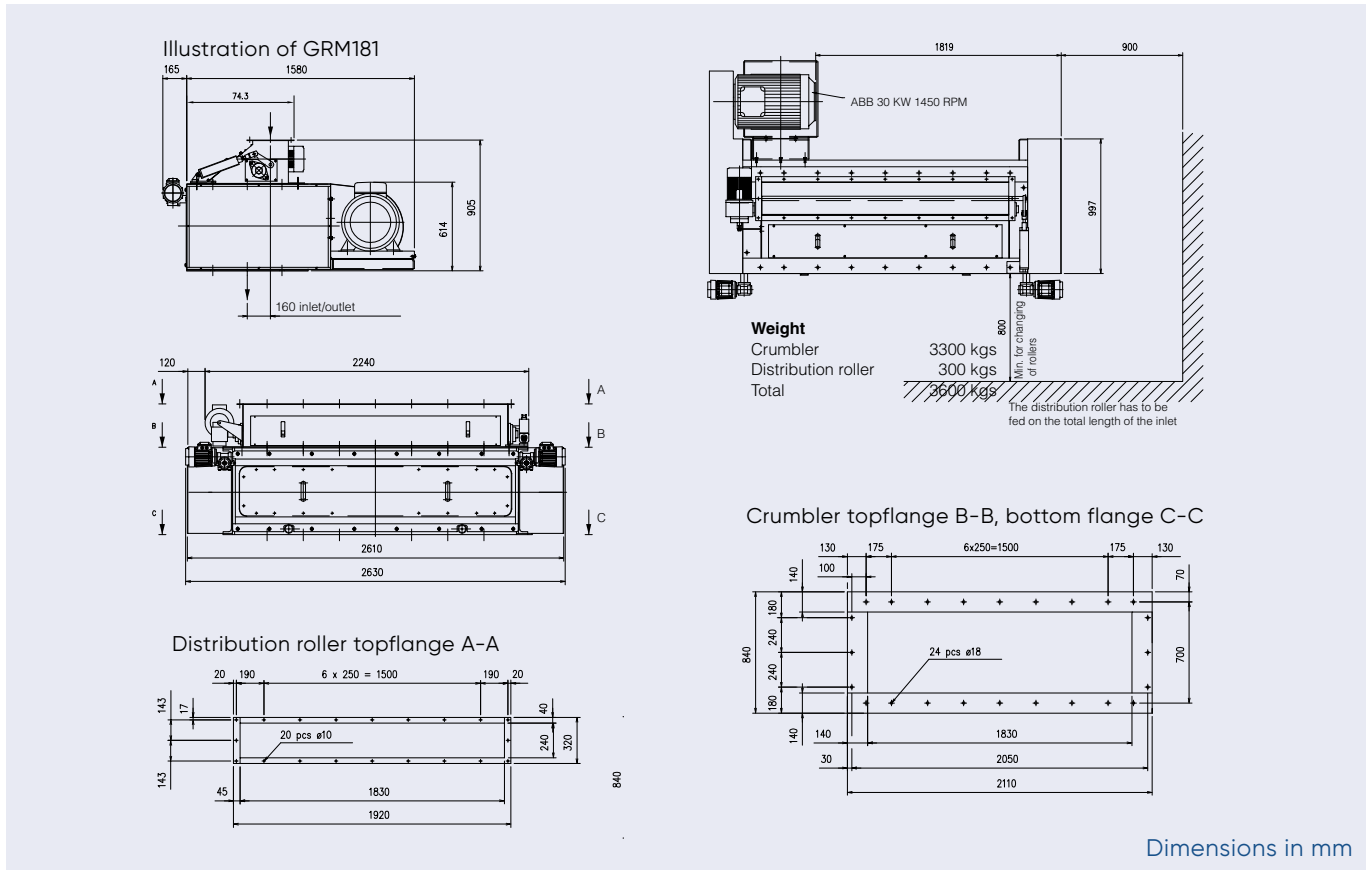

Dimensions in mm

TECHNICAL DATA

Type	Motor	Roller dia- meter	Roller length	Velocity V-belt drive	Roller adjust- ment	Option	Capacity Danish chicken feed	Distri- bution roller	Flap box (option)	Total weight
		ø	mm	A: 8.0/8.0 m/sec. B: 11.4/11.4 m/sec (standard)	manual gear motor	electric				kg
GRM121	max 30 kW (40 HP) 50/60 Hz	ø300	1200	x	0.12 kW (0.16 HP)	x	12-30 tph	0.75 kW (1 HP)	pneumatic	2780
	1460/1750 rpm									
GRM181	30 kW (40 HP) 50/60 Hz	ø300	1835	x	0.12 kW (0.16 HP)	x	20-40 tph	0.75 kW (1 HP)	pneumatic	3600
	1460/1750 rpm									

ANDRITZ Feed and Biofuel A/S

andritz-fb.dk@andritz.com

p: +45 72 160 300 / andritz.com/ft



All data, information, statements, photographs and graphic illustrations in this leaflet are without any obligation and raise no liabilities to or form part of any sales contracts of ANDRITZ AG or any affiliates for equipment and/or systems referred to herein. © ANDRITZ AG 2021. All rights reserved. No part of this copyrighted work may be reproduced, modified or distributed in any form or by any means, or stored in any database or retrieval system, without the prior written permission of ANDRITZ AG or its affiliates. Due to legal requirements, we must inform you that ANDRITZ AG processes your data for the purposes informing you about the ANDRITZ GROUP and its activities. Find out more details about our data privacy declaration and your rights under the data protection legislation on our website: andritz.com/privacy. ANDRITZ AG, Stattegger Strasse 18, 8045 Graz, Austria.



B 0718

1166 GB